

# **DDC-RE-01**

**IQRF Development Daisy Chain**

**Relay kit**

**User's Guide**



## Description

A relay development kit for IQRF wireless applications with (DC)TR transceiver modules plugged in DK-EVAL-04(A) kit. Compatible with other DDC (Development Daisy Chain) kits.

Ready-to-use example is available to demonstrate wireless relay control.

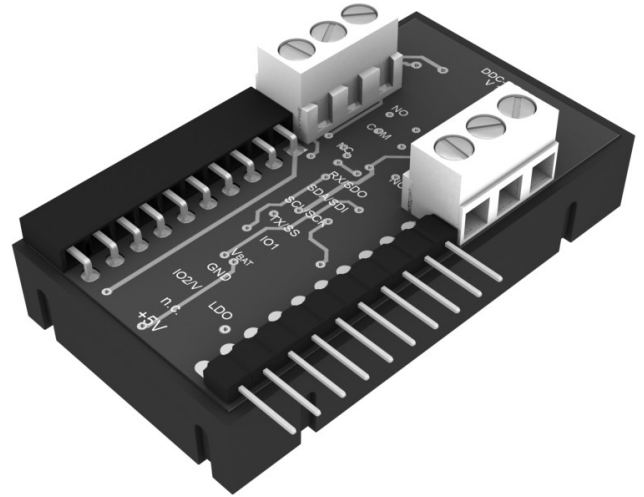

## Applications

- Development of IQRF applications
- Wireless relays
- Suitable also for networks

## Key features

- Compatible with other IQRF DDC kits
- Supplied from DK-EVAL-04(A)
- 2 bistable relays
- Simple control via one pin per relay

## Simplified schematics

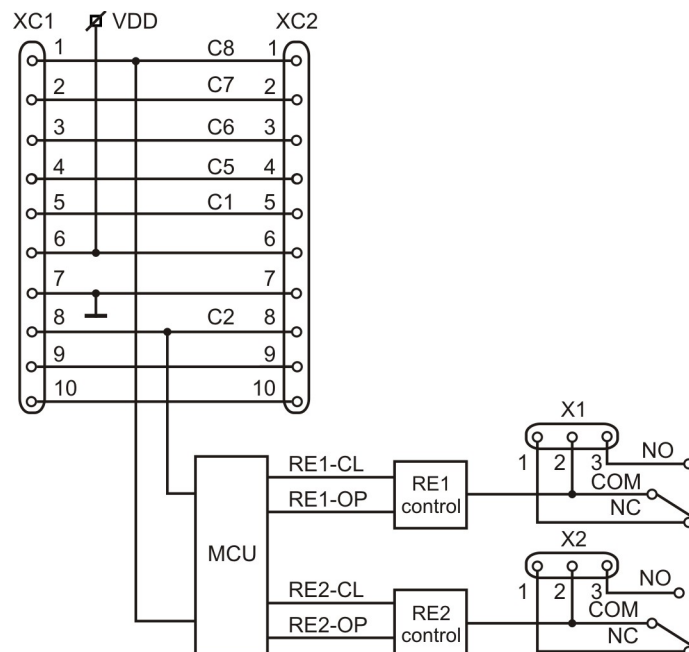

## Electrical specifications

(typical values unless otherwise stated)

Power supply (VDD)	3.3 V to 4.2 V DC
Supply current	
when not switching	5 $\mu$ A max.
while switching	50 mA for 12 ms max.
Switch signal duration	100 ms min.
Temperature range	-40 °C to +70 °C
Relays	
Contact rating	0.5 A 24 V AC/DC max.
Dimensions	48 mm x 27 mm x 11 mm
Weight	13 g

## Absolute maximum ratings

Stresses above those values may cause permanent damage to the device. Exposure to maximum rating conditions for extended periods may affect device reliability.

Supply voltage:	6.0 V
Storage temperature:	-40 °C to +85 °C

## Hardware

### Power supply

DDC-RE-01 should be supplied from DK-EVAL-04(A) via connector XC2.

### Interface connectors

The XC2 male connector with square 0.635 mm, 2.54 mm pitch pins is intended for I/Os and power supply.

Corresponding XC1 female connector serves for interconnection with other DDC kits.

X1 and X2 clamp connectors to connect contacts of the relays.

### Control circuitry

To simplify wireless control of relays and reduce power consumption, the kit is equipped with MCU and control circuitry. Thus, relays are driven according to the level of control pins (C8 for RE1 and C2 for RE2). Normally open contact is open when the control pin is set to low level.

### Relays

FTR-B3GB003Z miniature 2-contact bistable (latching) signal relays by Fujitsu are used. For higher contact rating both contacts are connected in parallel.

Refer to datasheets of the relay.

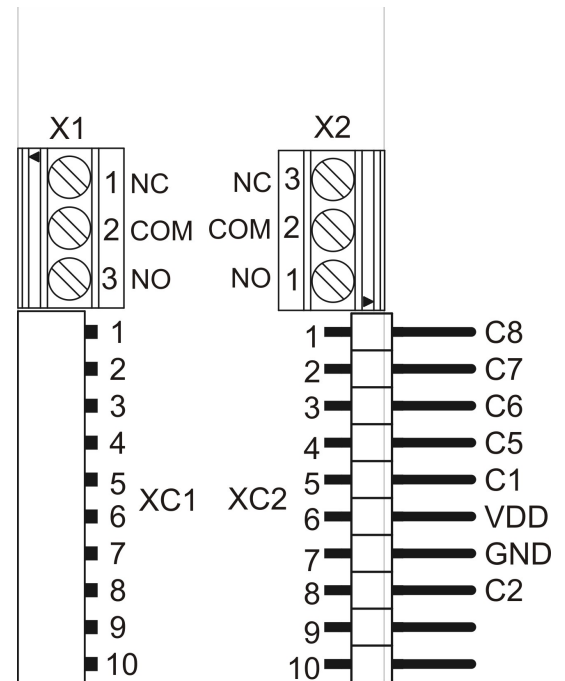

## Software

Ready-to-use examples are available in Startup package at [www.iqrf.org](http://www.iqrf.org).

---

**Product information**

---

**Pack list**

- DDC-RE-01                    DDC relay kit

**Recommended options**

- DK-EVAL-04A                IQRF development kit for TR modules
- DDC-IO-01                    DDC input/output kit
- DDC-SE-01                    DDC sensor kit

**Ordering code**

- DDC-RE-01                    IQRF relay DDC kit

**Document history**

- 150810                         Relay contact rating and temperature range revised. Some other minor revisions.
- 110415                         First release

---

# Sales and Service

---

## Corporate office

MICRORISC s.r.o., Prumyslova 1275, 506 01 Jicin, Czech Republic, EU  
Tel: +420 493 538 125, Fax: +420 493 538 126, [www.microrisc.com](http://www.microrisc.com)

## Partners and distribution

Please visit [www.iqrf.org/partners](http://www.iqrf.org/partners)

---

## Quality management

*ISO 9001 : 2009 certified*

*Complies with Directive 2002/95/EC (RoHS)*



## Trademarks

*The IQRF name and logo and MICRORISC name are registered trademarks of MICRORISC s.r.o.  
PIC, SPI, Microchip and all other trademarks mentioned herein are property of their respective owners.*

## Legal

*All information contained in this publication is intended through suggestion only and may be superseded by updates without prior notice. No representation or warranty is given and no liability is assumed by MICRORISC s.r.o. with respect to the accuracy or use of such information.*

*Without written permission it is not allowed to copy or reproduce this information, even partially.*

*No licenses are conveyed, implicitly or otherwise, under any intellectual property rights.*

*The IQRF products utilize several patents (CZ, EU, US)*

---

**On-line support: [support@iqrf.org](mailto:support@iqrf.org)**

---



Smarter wireless. Simply.