

# RC4-01

**IQRF remote controller**

**User's guide**



Smarter Wireless. Simply.

## Description

RC4-01 is a universal user-programmable remote controller for IQRF platform. It is a generic device. Thus, the hardware is fixed and the user-specific functionality is achieved by the software developed by a user's application engineer. The code can be uploaded wirelessly.

## Key features

- IQRF transceiver TR-76DA inside
- Bidirectional RF communication providing high security in comparison to unidirectional systems
- 4 pushbuttons
- 2 LEDs (visible through one peephole)
- Ultra low power consumption
- Coin battery CR2450
- IP66 protection
- Programmable via RF (wireless upload). For development and service, also wired upload is possible.



## Applications

- Remote controller for arbitrary use
- Internet of Things

## Block schematics

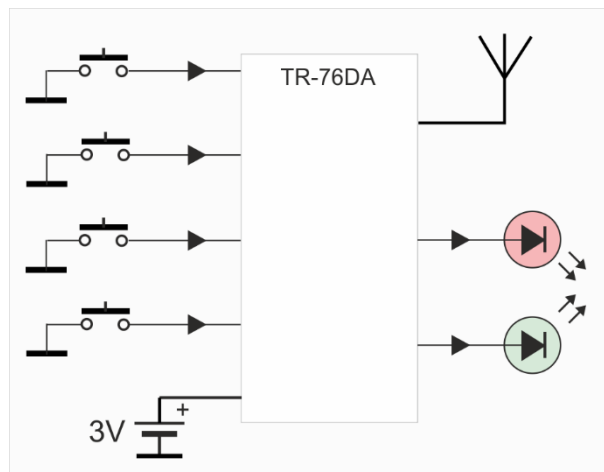

## Electrical specifications

Typical values (until otherwise specified)

RF transceiver	TR-76DA
Antenna	PCB meander built in the transceiver board
RF band	868 MHz or 916 MHz, multiple channels, SW selectable
Effective radiated power	Programmable in 8 levels up to the following values:
868 MHz band	6.5 dBm
916 MHz band	2.0 to 6.5 dBm (Depends on the RF channel. See TR-76D datasheet, diagram <i>ERP vs. channel</i> )
RF range	Up to 460 m <sup>1</sup> , up to 280 m <sup>2</sup>
Other RF parameters	See TR-76D datasheet
Battery	CR2450, 3V, 550 mAh, lithium coin cell 24.5 mm x 5 mm
Supply current	
TR in Deep sleep mode	100 nA (all TR peripherals inactive, LEDs off, pushbuttons not pressed)
TR in Sleep mode	700 nA (all TR peripherals inactive, LEDs off, pushbuttons not pressed)
Additional supply current	
TR not in sleep mode	See TR-76D datasheet
LED on	4 mA per LED (rough value for brief guidance only)
Pushbutton pressed	65 µA per pushbutton (rough value for brief guidance only)
Temperature	
Operating	-10 °C to +50 °C
Storage	-10 °C to +30 °C. Higher temperature impacts the battery lifetime.
Size	43 mm x 15.5 mm x 72 mm
Weight	34 g

**Note 1:** Arrangement: RC4-01 vertically, 1.6 m above the ground. Counterpart: TR-72DA transceiver plugged in DK-EVAL-04A kit, vertically, 1.6 m above the ground. Bidirectional communication, in free space.  
Test software: E09-LINK example (STD mode, `setRFpower(7)`, `checkRF(0)`).



**Note 2:** Arrangement: RC4-01 held in the hand, horizontally, with the longitudinal axis oriented towards the counterpart TR, 1.1 m above the ground. Counterpart: TR-72DA transceiver plugged in DK-EVAL-04A kit, vertically, 1.6 m above the ground. Bidirectional communication, in free space.  
Test software: E09-LINK example (STD mode, `setRFpower(7)`, `checkRF(0)`).



## Absolute maximum ratings

Stresses above those values may cause permanent damage to the device. Exposure to maximum rating conditions for extended periods may affect the device reliability.

Supply voltage	3.5 V
Storage temperature	-10 °C to +50 °C. Higher temperature impacts the battery lifetime.

## Hardware

### Simplified schematics

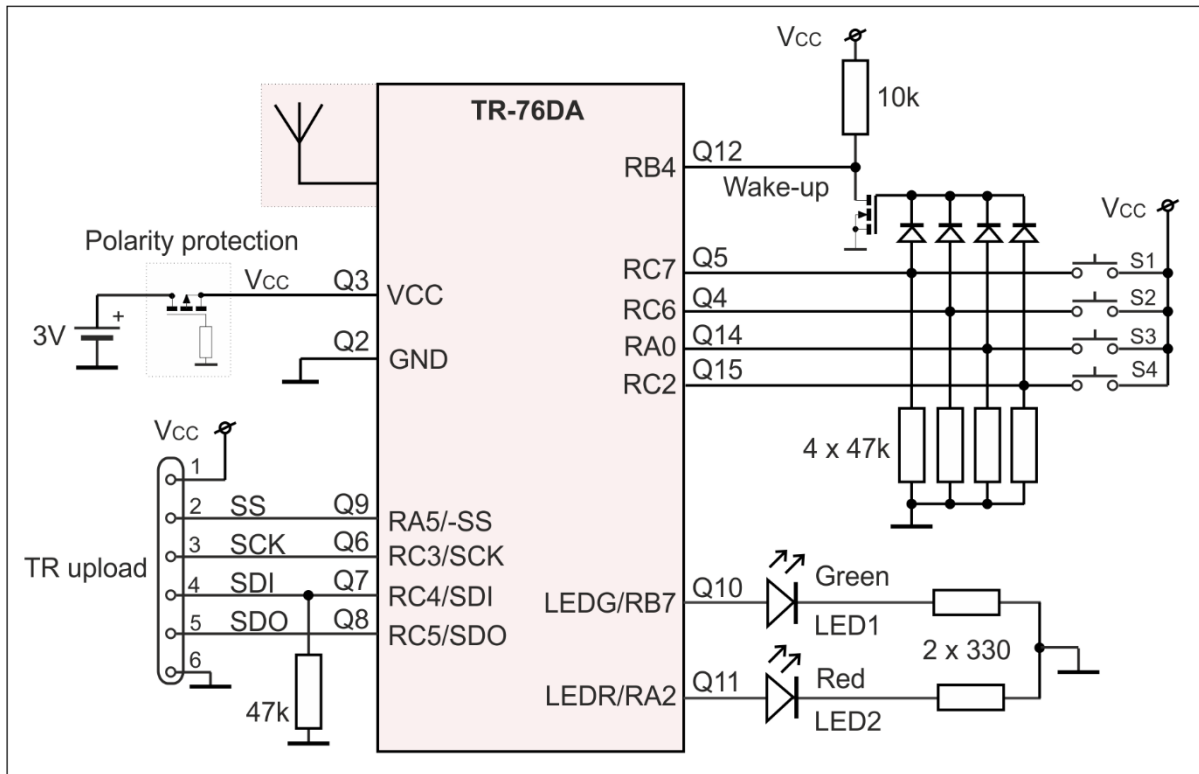

### Power supply

RC4-01 is supplied from the 3 V, 550 mAh lithium non-rechargeable coin 24.5 mm x 5 mm battery CR-2450. It is possible to use even a battery with higher capacity, e.g. 620 mAh. Exchanging is possible after unscrewing the rear cover. The polarity must correspond to the silkscreen marking at the bottom PCB side. RC4-01 is protected against damage due to the wrong polarity.

The power supply can not be switched off at all (unless removing the battery), the TR sleep mode should be used instead of this. See chapter *Sleep mode* below.

### TR transceiver

The TR-76DA transceiver with built-in PCB antenna is used.

Because the TR is soldered (non-removable), the recommended way to upload the application code into TR is wireless upload (RFPGM). Thus, the application engineer should keep a method how to enter RFPGM during development. See chapter *Demo application* for details.

However, it is also possible to use wired upload. In this case, the *TR upload* interface (with soldering pads only) is intended to connect the CK-USB-04A programmer by wires. Refer to the *CK-USB-04A User's guide*, chapter *In-circuit upload*.

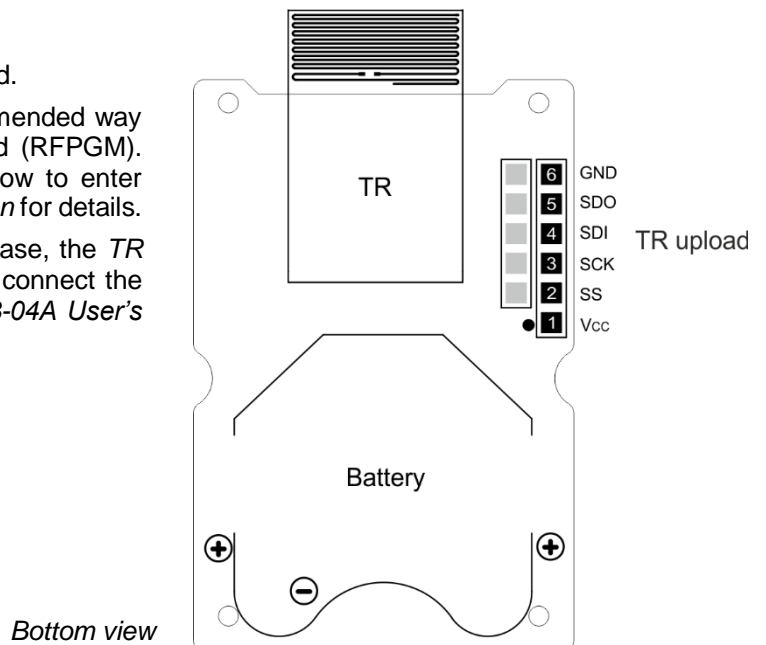

## Pushbuttons

The functionality of all four pushbuttons S1 to S4 is fully under control of the application software.

All pushbuttons are active at log. high level. To provide log. low level in the inactive state, the pushbutton pins have on-board pull-down resistors.

The pushbuttons have no hardware protection against contact bouncing when pressed and released. The protection should be ensured in software.

Arrangement:

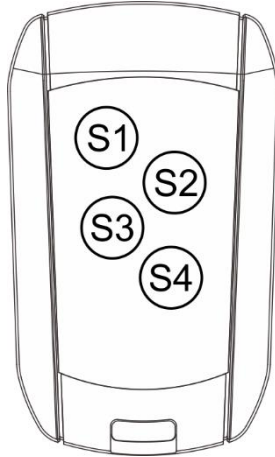

## LEDs

Green LED and red LED are connected to TR pins dedicated to IQRF OS and DPA indication. Additionally, during normal operation, the functionality of both LEDs is under control of application software. They are active at log. high level.

Both LEDs are visible through one peephole.

## Hardware revision

v1.01 First release.

---

## Operation

---

### Battery low indication

OS function `getSupplyVoltage()` should be used to check the battery. The Demo example uses approx. 2.6 V as the threshold voltage.

### Sleep mode

To minimize the supply current, it is possible to switch off all functions and peripherals and put the TR into Sleep mode. Wake-up is possible when any pushbutton is pressed. For the Sleep mode configuration and control, refer to the Demo example included.

In special cases (e.g. for long-lasting storage), the Deep sleep mode with even less power consumption can be utilized.

### Pushbuttons

The protection against contact bouncing should be performed in software. See the Demo example.

Besides of the essential purpose (sending RF packets for remote control), the pushbuttons can also be used for other tasks, e.g. to switch the RC4-01 to/from the RFPGM mode (wireless TR upload). The Demo example illustrates launching RFPGM when the pushbuttons S3 and S4 are pressed long at the same time and premature terminating RFPGM by the short press of any pushbutton.

### LEDs

IQRF OS uses both LEDs for RFPGM mode indication. Refer to the *IQRF OS User's guide*, chapter *RFPGM* for description. The application SW can managed LEDs directly (e.g. `LEDR = 1;`) or utilizing the appropriate OS functions (e.g. `pulseLEDR()`).

## Demo application example

The RC4-01 functionality can be designed fully according to the user's desire. The Demo application example `RC4-01_demo` provided with this product can be used for non-networking applications, either as it is or it can freely be adapted as required. The Demo illustrates transmitting of unidirectional non-networking packets. They can be received e.g. by a TR-72DA transceiver with the `E03-TR` example uploaded. Every received packet is indicated by the red LED flash. Received data can be visualized e.g. when the receiving TR is plugged in the CK-USB-04A development kit connected to PC with the IQRF IDE Terminal running.

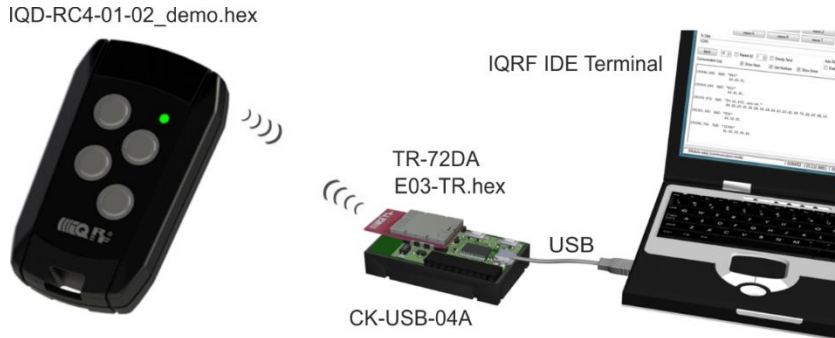

The Demo application can be downloaded from RC4-01 product page and `E03-TR` is one of IQRF Basic examples, available in the IQRF Startup package. To upload the Demo `.HEX` file via RF, see the *IQRF OS User's guide, Appendix RFPGM*. Switching to RFPGM mode after reset is enabled by default.

In the idle state, the controller stays in Sleep mode, allowing wake-up by any pushbutton. After wake-up, the battery voltage is checked and LEDs flashing indicates pressing the button and the accumulator condition. Then the respective command is performed and the controller gets to sleep again. Besides the information about the pushbutton, every transmitted packet also reports the battery status.

### Buttons

Buttons	Function	
• S1	Text sent: "S1x"	x=0 if battery O.K., otherwise x=1
• S2	Text sent: "S2x"	-"
• S3	Text sent: "S3x"	-"
• S4	Text sent: "S4x"	-"
• S3 and S4 for more than 5 s	Enter RFPGM mode	
• Any button for more than 0.7 s	Leave RFPGM mode	

### LED indication

- Button S1 to S4 pressed: 1 x flash green (battery O.K.) / red (battery exhausted).
- RFPGM indication: See the *IQRF OS User's guide, Appendix RFPGM*, indication in RFPGM LP mode.

This Demo can also plug-and-play remotely control the relays on IQRF development kit DDC-RE-01 in the following configuration:



See the comments in the DDC-RE-01 Demo example source code provided with this kit.

**Caution:** The Demo software version should correspond to IQRF OS version implemented in RC4-01.

To read out the OS version, catch *Module Info* which is always sent by this Demo application just before switching to RFPGM mode in IQRF IDE Terminal. The *Data HEX* checkbox should be activated for this. OS version is stored in buffer `moduleINFO[4]`. See the picture below and *IQRF OS Reference guide*.

Example:

```
moduleINFO[0-7]:
 [0] [1] [2] [3] [4] [5] [6] [7]
  D5 CF 10 81 42 B4 B8 08
moduleINFO[4] = 42 means OS v4.02D
```

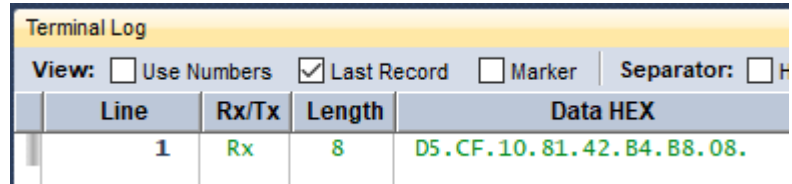

Terminal Log			
View: <input type="checkbox"/> Use Numbers <input checked="" type="checkbox"/> Last Record <input type="checkbox"/> Marker Separator: <input type="checkbox"/> H			
Line	Rx/Tx	Length	Data HEX
1	Rx	8	D5.CF.10.81.42.B4.B8.08.

**Caution:**

The standard way how to upload the user application into the RC4-01 is RFPGM (in-circuit wireless programming). The Demo application `RC4-01_demo.c` invokes the `enableRFPGM()` function first. It ensures that after every reset (due to reconnecting the battery) the device is switched to RFPGM mode and can possibly be reprogrammed. This feature can be removed (by `disableRFPGM()`), but it should not be done unless there is another reliable way how to invoke back the RFPGM mode using `runRFPGM()` after pressing a pushbutton. See the Demo application and refer to the *IQRF OS User's guide, Appendix RFPGM* for details. If being omitted, the device can not be reprogrammed wirelessly anymore until it is recovered by wired upload using the PCB pads inside the case only.

**Tip:** If wired upload via the PCB pads is not comfortable for you, always use `enableRFPGM()` during the development.



---

## Product information

---

### Ordering code

RC4-01                      Generic IQRF remote controller

### Supplied contents

RC4-01                      Generic IQRF remote controller. TR-76DA inside, with RC4-01\_demo uploaded, TR in sleep when delivered from the factory.

BK-CR2450-1B              Lithium coin cell battery CR2450 (550 mAh) inside

Charm chain                Not included

### Hardware revision

v1.01                        First release

### Document history

180629                      First release

---

# Sales and Service

---

## Corporate office

MICRORISC s.r.o., Prumyslova 1275, 506 01 Jicin, Czech Republic, EU  
Tel: +420 493 538 125, Fax: +420 493 538 126, [www.microrisc.com](http://www.microrisc.com)  
E-mail (commercial matters): [sales@microrisc.com](mailto:sales@microrisc.com)

## Technology and development

[www.iqrf.org](http://www.iqrf.org)  
E-mail (technical matters): [support@iqrf.org](mailto:support@iqrf.org)

## Partners and distribution

[www.iqrf.org/partners](http://www.iqrf.org/partners)

---

## Quality management

*ISO 9001 : 2009 certified*

*Complies with ETSI directives EN 301 489-1 V1.9.2:2011, EN 301 489-3 V1.6.1:2013, EN 300 220-1 V3.1.1:2017, EN 300 220-2 V3.2.0:2017 and ERC Recommendation 70-03 (2017) and VO-R/10/05.2014-3.*

*Complies with directives 2011/65/EU (RoHS) and 2012/19/EU (WEEE).*



## Trademarks

*The IQRF name and logo are registered trademarks of IQRF Tech s.r.o.  
PIC, SPI, Microchip and all other trademarks mentioned herein are the property of their respective owners.*

## Legal

*All information contained in this publication is intended through suggestion only and may be superseded by updates without prior notice. No representation or warranty is given and no liability is assumed by IQRF Tech s.r.o. with respect to the accuracy or use of such information.*

*Without written permission, it is not allowed to copy or reproduce this information, even partially.*

*No licenses are conveyed, implicitly or otherwise, under any intellectual property rights.*

*The IQRF® products utilize several patents (CZ, EU, US).*

---

**On-line support:** [support@iqrf.org](mailto:support@iqrf.org)

---



Smarter Wireless. Simply.